



HELIUM 2.0

RENTAL LED CABINET FOR CUBIC APPLICATIONS

COMPATIBLE WITH THE BERYL AND THE BORON 2.0









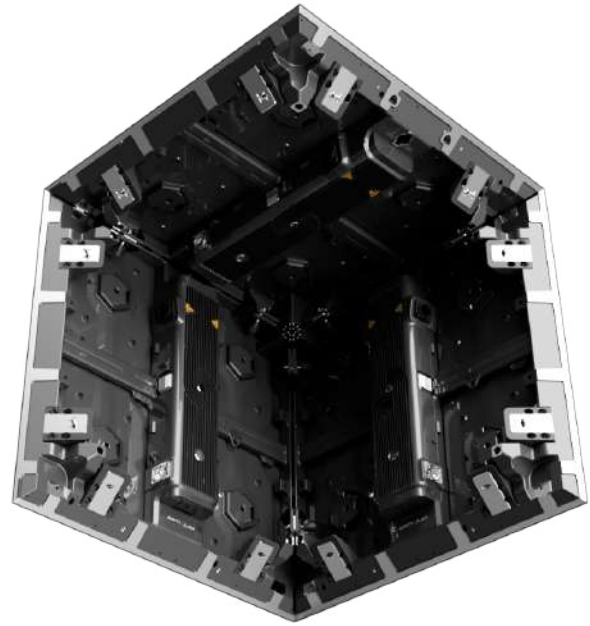



OVERVIEW

Designed for cubic and 90° applications, this LED cabinet, available in P1.9, P2.6, P2.9, and P3.9, is fully compatible with our renowned BERYL and BORON 2.0 touring cabinets, making it the ideal solution to expand the capabilities of your touring LED cabinet fleet. Equipped with all the usual touring-oriented features, such as toolless locking systems, integrated handles, and front & rear maintenance, this product stands out for its versatility, thanks to flat or 45° add-ons that can be inverted on all four sides of the frame.



-  APPLICATION
Indoor
-  INGRESS PROTECTION
IP20
-  PIXEL PITCH
P1.9 P2.6 P2.9 P3.9
-  DISPLAY AREA (W x H)
500 x 500 mm
-  BRIGHTNESS
≤ 1300 NITS
-  WEIGHT
6 kg/cabinet
-  MATERIAL
Die-casting aluminum
-  MAINTENANCE
Front & back maintenance



FEATURES

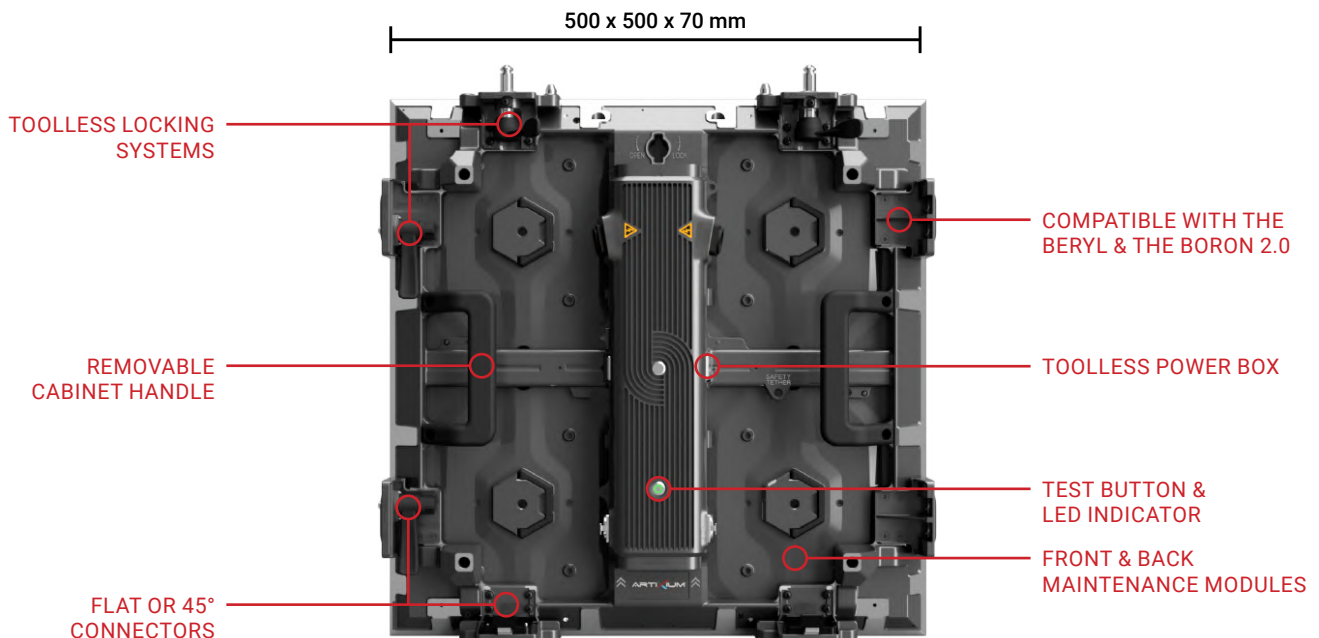

MINILED 4IN1

The HELIUM 2.0, in its P1.9 and P2.6 variants, integrates cutting-edge MiniLED 4in1 technology. This innovation encapsulates four smaller LEDs within the footprint of a traditional SMD LED, resulting in superior image resolution and enhanced durability. The encapsulation not only increases the LED's resistance to physical stress but also facilitates individual LED repairs, ensuring prolonged operational efficiency. By adopting this advanced technology, the HELIUM 2.0 delivers vibrant visuals and robust performance, making it an ideal choice for dynamic touring environments.

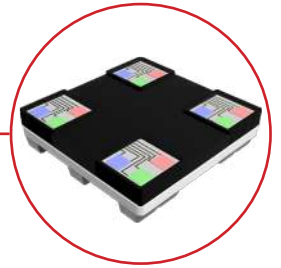

TOURING ORIENTED FEATURES

HELIUM 2.0 comes equipped with all the essential touring-oriented features, from ergonomic handles and toolless locking systems to front and rear maintenance access. Fully compatible with the BE-RYL's hanging bar/stacking system, it ensures seamless integration into your existing touring infrastructure.

EASY MAINTENANCE

Designed with efficiency in mind, the HELIUM 2.0 allows for quick and easy servicing from both the front and rear of the cabinet. Thanks to its magnetic modules & toolless power box, maintenance operations are streamlined, minimizing downtime and keeping your set-up running smoothly, even under tight event schedules.

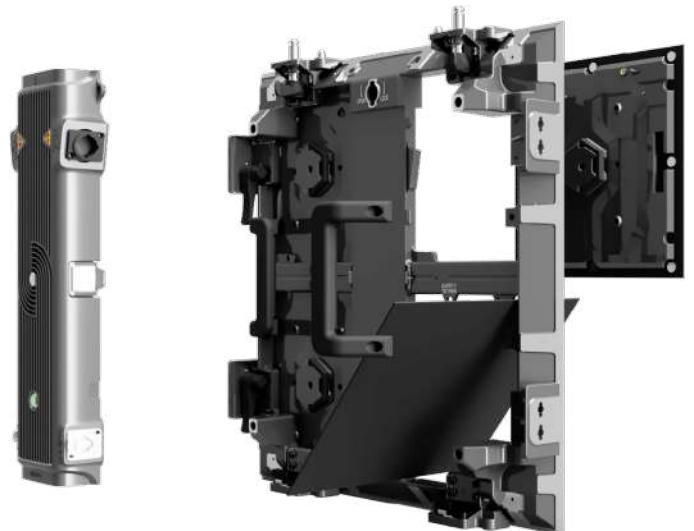

CABINET ADD-ONS

The HELIUM 2.0 pushes modular design even further with its innovative four-side add-on system. Whether you're working with flat edges or aiming for dynamic 90° angles, each side of the cabinet frame can be individually equipped and

inverted to meet your creative and technical requirements. This smart design ensures maximum flexibility for cubic setups, creative builds, and seamless integration with the rest of your touring fleet.

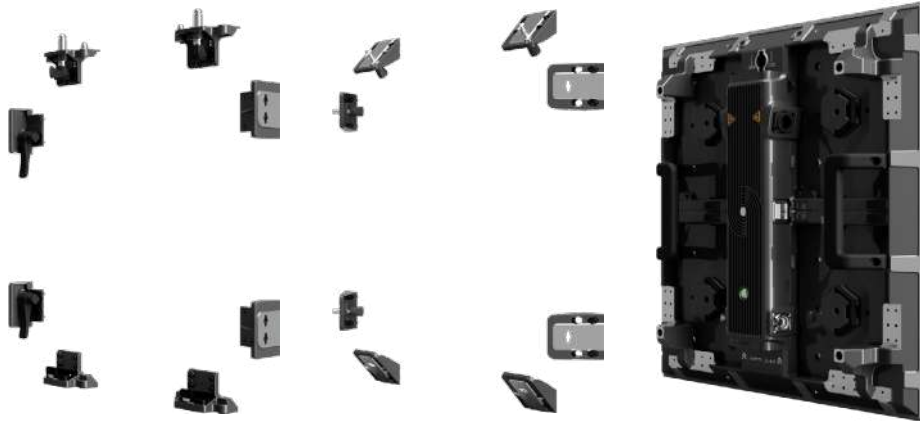

CROSS-COMPATIBILITY

The HELIUM 2.0 enhances our PRO TOURING lineup with exceptional compatibility features. It seamlessly integrates side-to-side with the BORON 2.0 and offers both side-to-side and top-to-bottom compatibility with the BERYL,

providing unparalleled flexibility for your LED display configurations. This interoperability ensures that expanding and customizing your touring LED cabinet fleet is both efficient and straightforward.

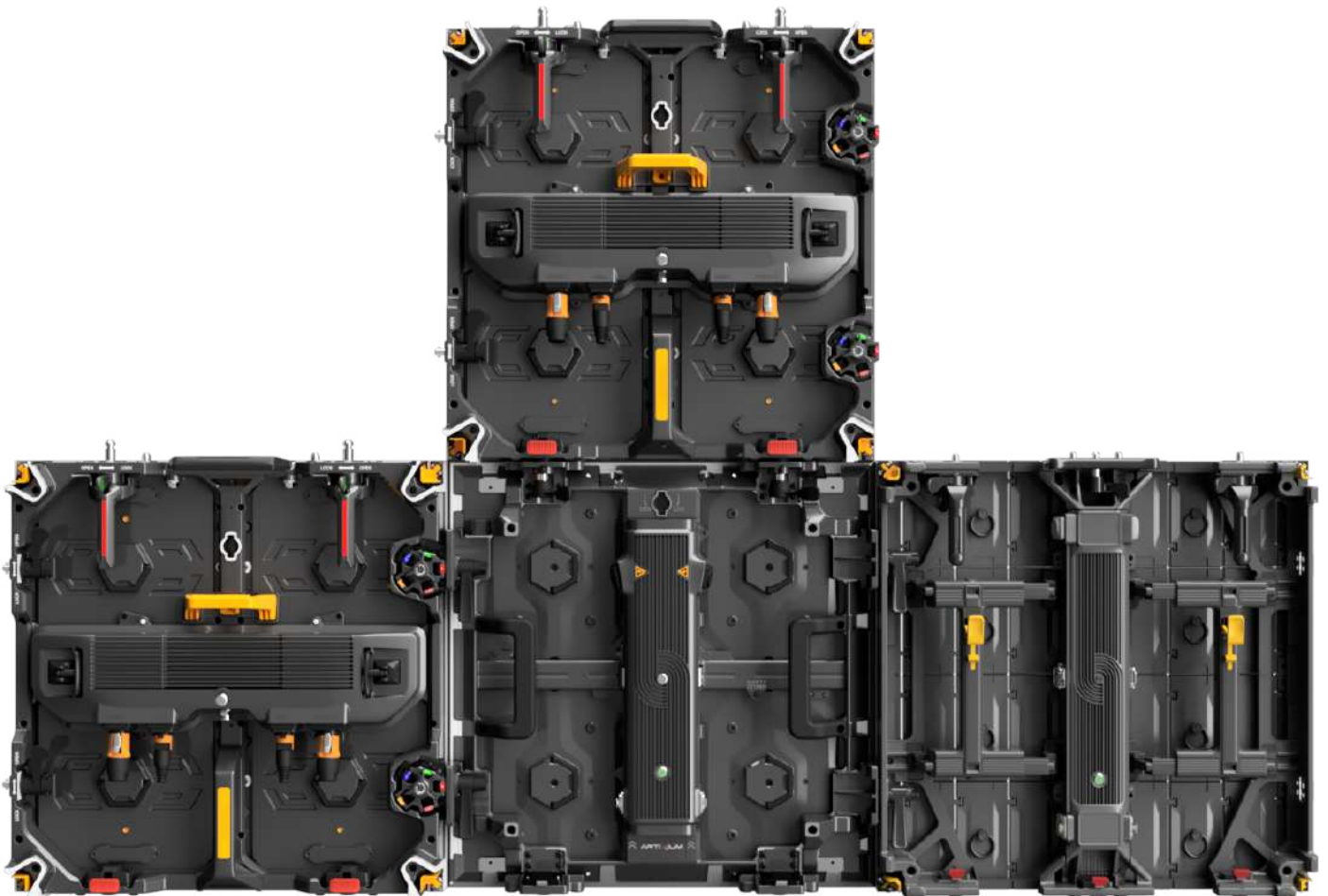

APPLICATION EXAMPLES

The following images showcase examples of HELIUM 2.0's cross-compatibility with other cabinets in the PRO TOURING range.

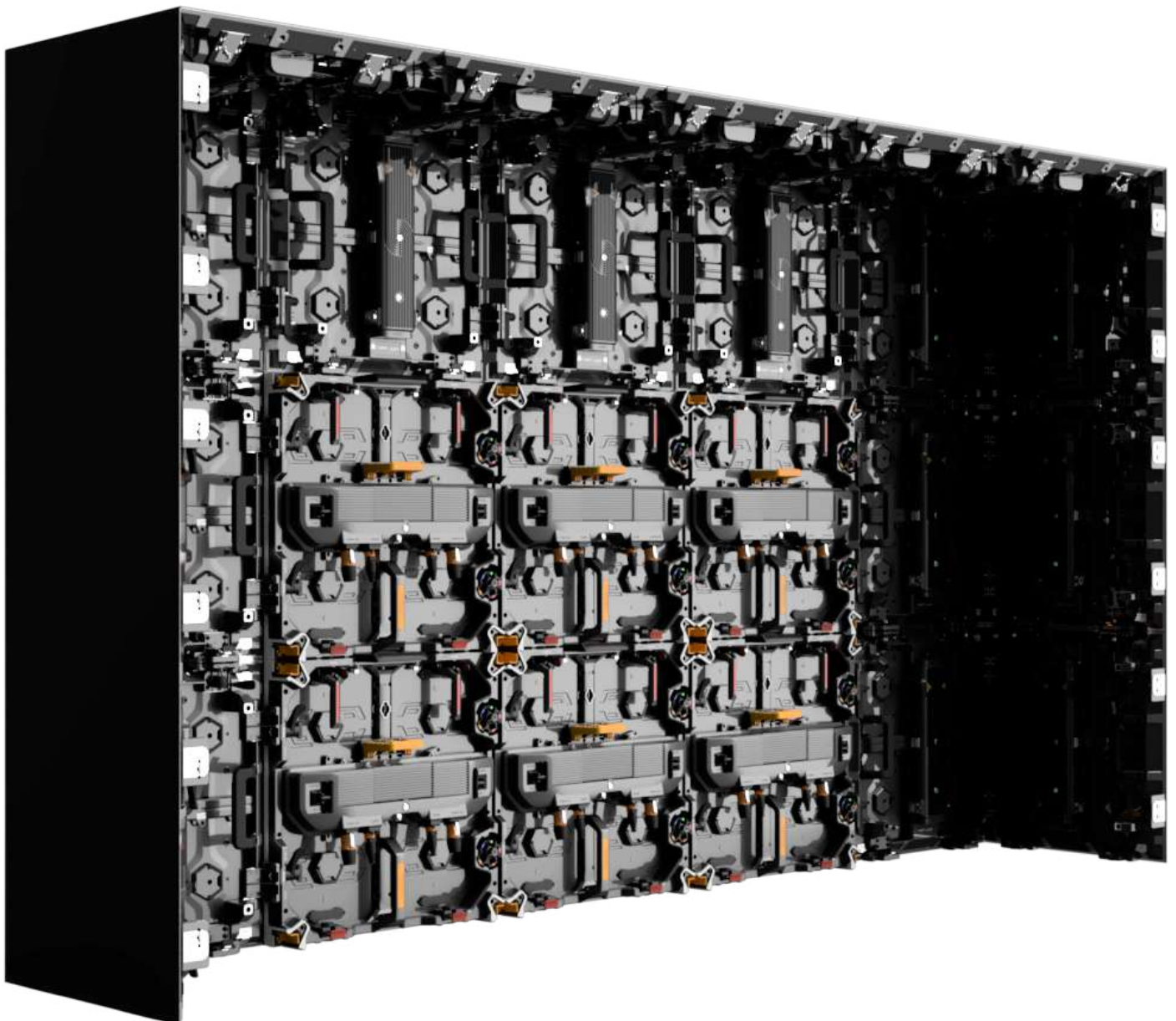
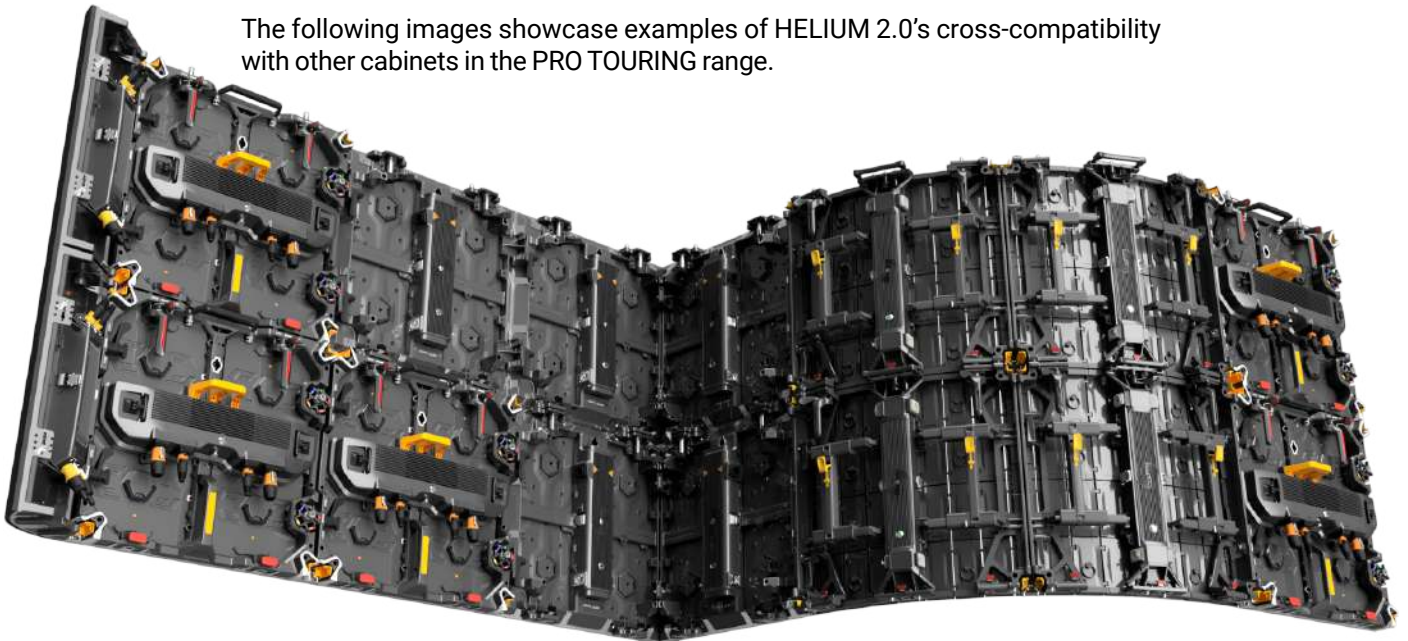



TECHNICAL SPECIFICATIONS

Product Parameters	Unit	INDOOR			
		1.9	2.6	2.9	3.9
Pixel Pitch	mm	1,95	2,60	2,98	3,91
LED		MiniLED 4in1		SMD2121	
Application		Rental display for cubic applications			
Ingress Protection	IP	IP20			
Brightness	cd/m ²	≤ 1000 Nits @5volts		≤ 1300 Nits @5volts	
Color Temperature after calib (adjustable)	deg. K	6500			
Viewing Angle (50% brightness)	deg.	160H / 80V			
Cabinet Size (WxHxD)	mm	500 x 500 x 70			
Display area (WxH)	mm	500 x 500			
Module Size (WxHxD)	mm	250 x 250			
Pixel Matrix Per Cabinet (WxH)	px	256 x 256	192 x 192	168 x 168	128 x 128
Pixel Matrix Per Module (WxH)	px	256 x 64	192 x 48	168 x 42	128 x 32
Pixel Density	px/m ²	262144	147456	112896	65536
Weight of cabinet and modules	kg	6			
Cabinet Material		Die-casting aluminum			
Maintenance Mode		Front & Back			
Mask specification		95% Plastic + 5% Fiber / SS Screws / No shaders			
Contrast Ratio		High			
Grey scale (linear)	bit	16			
Brightness control	bit	16			
Processing depth	bit	16			
Color		281 Trillions			
Display Refresh Rate	Hz	3840			
Operation Power	V	AC85-230V			
Max. Power Consumption	W/m ²	550	500	450	
Average Power Consumption	W/m ²	168	150	135	
Control Mode		Synchronization			
Video Frame Rate	Hz	50/60Hz			
Input Types Supported		DVI / SDI / HDMI			
3D ready (optional)		Yes			
Calibration		Yes			
Lifetime (50% brightness)	h	50000			
Operating Humidity Range		10-90%			
Operating Temperature Range		-20°C / +50°C			
Screen Uniformity Correction		-			
Certification		CE / ETL / CCC / CB / FCC / PSE			
Options		Hanging bars / stacking system			
Compatibility		Compatible with the BERYL & the BORON 2.0			



TECHNICAL DRAWINGS

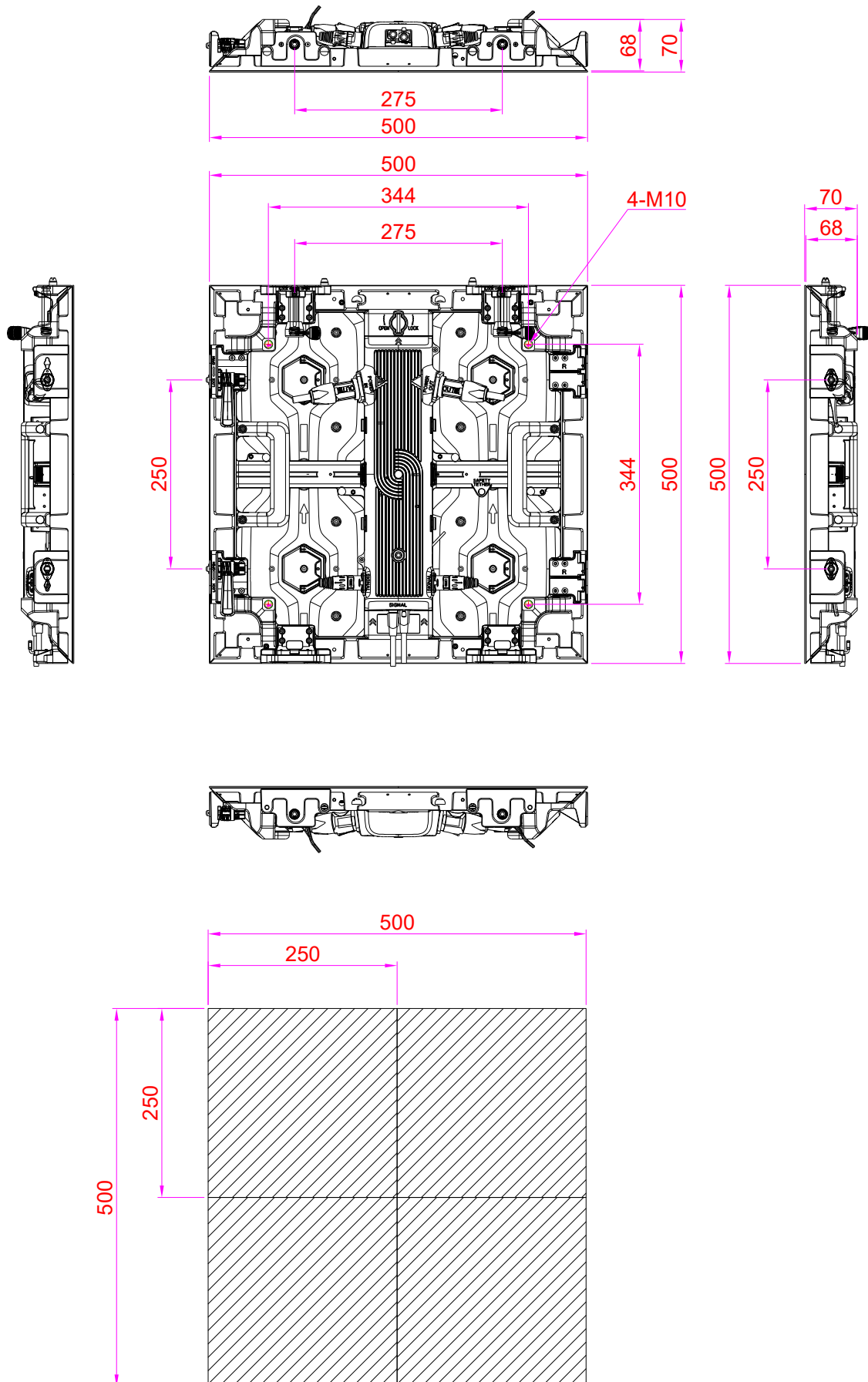



CONTACT

The Artixium regional branches are the key for the growth and development of our global network all over the world. Artixium's team is a spectrum of different nationalities and cultures, reflecting their global presence and mindset, mak-

ing their communication smooth and hassle-free with clients from all around the world. Customer care, Innovation and flexibility has always been our values and we intend to keep this reputation for many years to come.

ARTIXIUM FRANCHISES

"From your project's conception to its completion."



112 Avenue Franklin Roosevelt
69120 Vaulx-en-Velin
France



Artixium Operational Center
518000 Shenzhen
China



Weissensteinstrasse 90b,
46149 Oberhausen
Germany



Merkez Mah. Baglar Cad. A
Blok Apt. No: 14D/13 Kagithane, Istanbul
Turkey



 www.artixium.com

 0 428 001 801

 [linkedin.com/company/artixium](https://www.linkedin.com/company/artixium)

 twitter.com/artixium

 contact@artixium.com

 [youtube.com/@artixium](https://www.youtube.com/@artixium)

 [facebook.com/artixiumdisplayltd](https://www.facebook.com/artixiumdisplayltd)

 [instagram.com/artixium](https://www.instagram.com/artixium)



Since its creation in 2012 by two european entrepreneurs, Artixium has been evolving and always looking for innovative ways to contribute to the digital transition of our world. It only took a few years for Artixium to become a key player in the LED display industry.

www.artixium.com